

C80

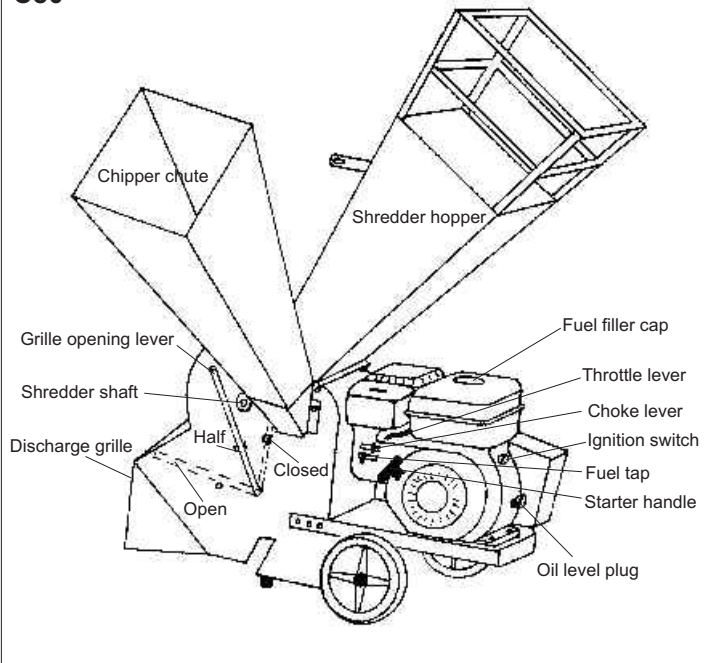

**OPERATING  
INSTRUCTIONS  
&  
SAFETY NOTES**

C150

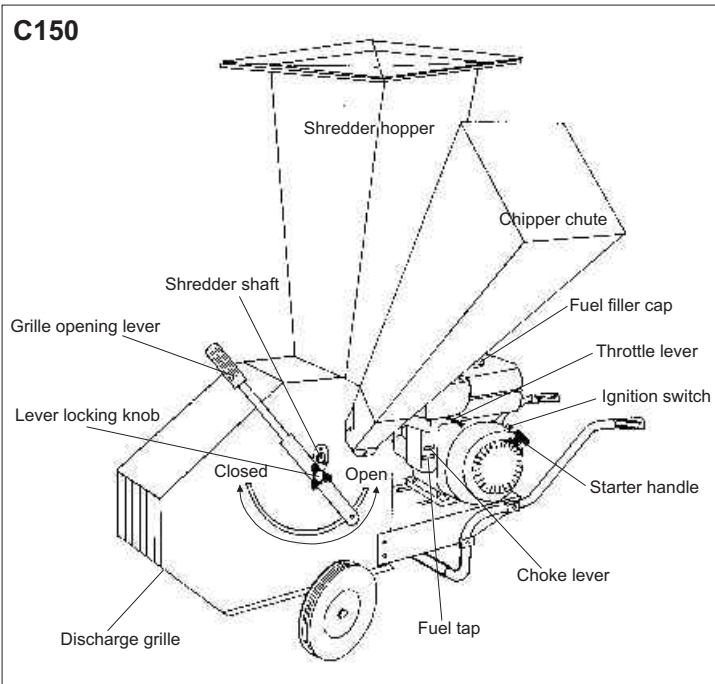

**CAMON**  
**CHIPPER-SHREDDERS**  
**C80 • C150**

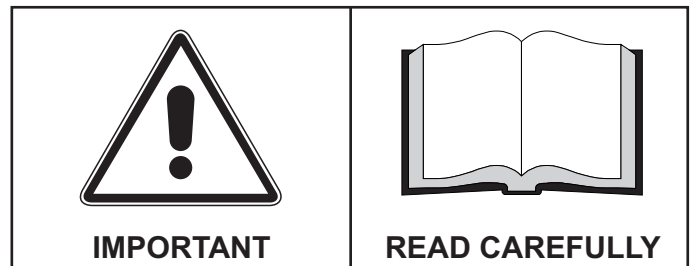

SOUND LEVELS	
Machine	Sound Level dB(A)
C80 Chipper-Shredder	up to 98.0
C150 Chipper-Shredder	up to 104.0



**WEAR EAR  
PROTECTION**



**WEAR EYE  
PROTECTION**



**WEAR SAFETY  
FOOTWEAR**

## SAFETY

- ALWAYS** start the engine in the open air
- DO NOT** smoke when refuelling
- DO NOT** mix OIL with the fuel
- ALWAYS** stop the engine before making any adjustments, refuelling, moving or cleaning, or when the unit is unattended
- USE ONLY** unleaded petrol from clean containers designed for this purpose - refuel outdoors only and replace the tank cap securely
- IN CASE** of petrol spillage, move the machine away from the area of spillage and allow the vapours to dissipate before starting the engine
- ALWAYS** ensure that guards are in place when the machine is operating or the engine is running
- DO NOT** remove any safety guards that are fitted
- DO NOT** touch any moving parts or attempt any maintenance whilst the machine is running - **KEEP HANDS AND FEET AWAY**
- ALWAYS** wear safety glasses and ear protectors
- DO NOT** allow children or anyone uninstructed to operate the machine - **KEEP ANIMALS AWAY**
- ALWAYS** wear suitable clothing to give personal protection
- KEEP** hands, feet and clothing out of openings, discharge and moving parts when the machine is operating or the engine is running
- KNOW** how to stop the machine in an emergency
- NEVER** interfere with any control settings on the engine
- IF A FAULT** develops **DO NOT** attempt any repair - immediately contact the supplier from whom the machine was obtained
- VISUALLY INSPECT** the machine before use - ensure all nuts and bolts are tight and not worn or damaged
- KEEP IN MIND** the operator is responsible for accidents or hazards occurring to people or property

## BEFORE STARTING

- Ensure the machine is on firm, level ground.
- DO NOT USE MACHINE ON A SLOPE.**
- The unit may be placed on a tarpaulin to collect the processed material.
- Ensure the shredder hopper and chipping chute are in place.
- Using the dipstick provided, check the engine oil level. Top up with 10w/40 oil if necessary (if the dipstick is clear of oil).
- Check fuel level. Only use unleaded petrol from a clean container. Never re-fuel when the engine is hot or running. Leave 1" air space in the fuel tank.
- Ensure the discharge grille is fully closed.

## TO START ENGINE

- Switch on ignition and if the engine is cold, apply the choke.
- Turn on the fuel tap and apply half throttle.
- Engage the recoil starter and pull handle firmly.
- Once the engine has started, release the choke after a few seconds and return throttle to idle position.

## SHREDDER OPERATION

- ENSURE THE DISCHARGE GRILLE IS IN THE CLOSED POSITION.**
- Increase engine to FULL throttle and allow the machine to build up to FULL speed.
- Be very careful what you put into the hopper.
- The shredder cannot handle: cloth, string, plastics, glass, rubber, stones, bricks, large wood chunks, metal, thick branches or long vines.
- NEVER** be tempted to drop short end pieces into the hopper as the **HAMMER BLADES** will jam causing damage to the drive system.
- Wet green garden waste and wet grass clippings may require mixing in with some dry wood to avoid clogging the shredder. If necessary move discharge grille lever to half open position when shredding wet material.
- Adding too much material at a time can clog the shredder - allow the machine to clear itself each time.
- DO NOT** throw thin branches into the hopper with a spearing force as this will overfeed the hammer blades and jam the machine.
- FAILURE TO OBSERVE THIS PRECAUTION WILL CAUSE DAMAGE TO THE CLUTCH AND DRIVE BELTS.**

## TO CLEAR DISCHARGE GRILLE

- Switch off the engine and visually check the shredder shaft has stopped rotating.
- Disconnect the spark plug lead.
- Move discharge grille lever from fully closed to fully open position.
- Clear out the material with a wooden handle or brush.
- DO NOT** reach inside with fingers as the hammer blades are sharp.
- Close discharge grille fully.
- Reconnect the spark plug lead.

## DANGER POINTS TO OBSERVE

- The chipper shredder blades may continue to rotate silently after engine shut down.
- Be sure the blades have stopped rotating before working on the machine.
- The shredder grasps and pulls material down into the hopper with surprising speed.
- Clear processed material regularly do not allow it to build up underneath the machine.
- Gloves, if worn for shredding, should be large enough to slip off your hands if caught in the material.
- DO NOT** wear rings, bracelets, watches or jewellery or any other items that could be caught in the material and draw your hands into the shredder. Hold the material very lightly.
- DO NOT** use the machine with the discharge grille **FULLY OPEN.**
- NEVER** attempt to operate the machine without chipper chute and shredder hopper in place.
- NEVER** overload the machine.
- NEVER** stand in front of the chipper chute or attempt to look down the shredder hopper when the machine is operating.
- NEVER** position the machine on a ledge higher or lower than the operator. Machine and operator must be on the same level.
- ALWAYS** operate the machine a FULL throttle.
- ALWAYS** allow the machine to run at full speed for 2 minutes before switching off.
- FAILURE TO OBSERVE THESE POINTS MAY RESULT IN PERSONAL INJURY.**